

# **MSP430 Capacitive Single-Touch Sensor Design Guide**

Vincent Chan, Steve Underwood

MSP430

## **ABSTRACT**

This application report discusses the design of RC-type capacitive single-touch sensors using the MSP430 microcontroller. The MSP430 has some unique features that make it suitable for interfacing with capacitive-touch sensors. The RC-type method does not need special peripherals and can be implemented with all devices in the MSP430 product family. This method is also inherently low power and can provide very low-power implementations.

This application report includes guidelines for use when implementing capacitive sensors in products.

## **Contents**

1	Principle of Operation .....	2
2	Basic Capacitance Measurement .....	2
3	Techniques to Improve Noise Immunity and Increase Sensitivity.....	3
4	Processing Measurement Result .....	7
5	Building an Experimental Board .....	8
6	System Resources .....	11
7	Board Layout Considerations.....	11
8	Overlay .....	13
9	References.....	18

## **List of Figures**

1	Open Capacitor Acting as a Sensor.....	2
2	Charge-Discharge Sequence .....	3
3	Measurement Cycle for Improved Noise Rejection .....	4
4	Multi-Sensor Charge/Discharge Configuration.....	4
5	Software Low-Pass Filter .....	5
6	Oscilloscope With Mains Noise .....	5
7	Oscilloscope With IIR Filter.....	5
8	Tracking Base Capacitance Flow Chart .....	6
9	Slider Function .....	7
10	Weighted Averaging Method .....	7
11	Slider Output Steps.....	7
12	MSP430 Experimenter's Board .....	8
13	Experimenter's Board Pad Layout.....	9
14	Touchpad Processor.....	10
15	Touchpad Size and Shape.....	11
16	Pad Sensitivity (Overlay Thickness = 0 mm) .....	12
17	Pad Sensitivity (Overlay Thickness = 0.8 mm).....	12
18	Pad Sensitivity (Overlay Thickness = 2.4 mm).....	13
19	Overlay Thickness vs Sensitivity .....	15
20	Effects of Clearance and Overlay Thickness vs Sensitivity .....	15
21	RF Emissions .....	17
22	RF Interference Susceptibility .....	18

## 1 Principle of Operation

A single-touch sensitive capacitor sensor can be constructed by "opening up" a capacitor structure so that the electric field can be interfered with by a conductive foreign object, in this case, a finger.

Figure 1 shows an example of such a capacitor constructed on a PCB. Here, a capacitor is formed between the pad and the ground surrounding it. The electric field is allowed to leak into the area above the capacitor. When a finger is put near an area above the capacitor, it interferes with the electric field, causing the resultant capacitance to change.

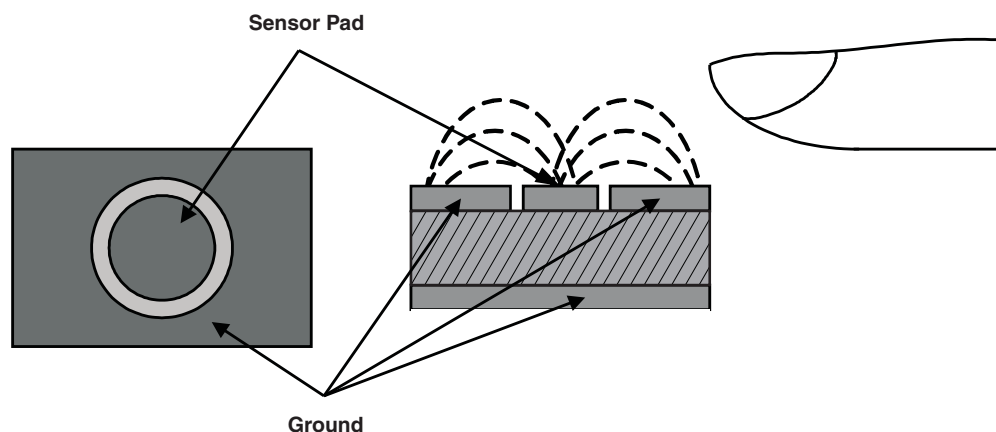

**Figure 1. Open Capacitor Acting as a Sensor**

Often a ground plate is put underneath the pad to shield it from the interference generated by other electronics. This type of design is affected by stray capacitance on the PCB and other environmental effects such as temperature, humidity, and so on. Therefore, the detection system needs to constantly monitor and track this variation.

## 2 Basic Capacitance Measurement

This section describes basic capacitance measurement using the RC charge and discharge method and hardware requirements.

The RC discharge time is used to measure the sensor capacitance. This method is described in a 1976 patent that is now expired. The capacitive sensor forms the C part of the RC circuit. A single I/O line is used to charge, discharge, and generate an interrupt when the voltage of the capacitor crosses a threshold.

The sequence of events is as follows:

1. One side of the resistor is connected to the sensor, the other side to ground. The sensor is connected to the I/O line.
2. The I/O port is set to output high. This charges the capacitive sensor to near  $V_{CC}$  very quickly. A free-running timer is read to mark the start time. This example uses TAR of Timer\_A.
3. The I/O is set to input with negative-edge interrupt enabled. The resistor then discharges the capacitive sensor. The microcontroller goes into low-power mode 0.
4. When the voltage of the sensor crosses  $V_{IL}$ , an interrupt is generated.
5. The interrupt service routine reads the free-running timer (TAR) again and calculates the time to discharge to  $V_{IL}$ .
6. The microcontroller exits the low-power mode and continues with operation.

The discharge time is proportional to the capacitance of the sensor pad. Therefore, to provide enough resolution for the measurement, the RC discharge must be sufficiently slow. To ensure a sufficient discharge time, a large-value resistor of approximately 6 MΩ is used. With this resistance, the charging current to the capacitor is only approximately 500 nA. Therefore, I/O ports with very low leakage are necessary.

The MSP430 has an I/O port leakage current of 50 nA maximum, which is suitable for sensing the capacitance with this method. Port 1 and Port 2 have eight independent interrupt lines each, giving a maximum of 16 sensors that can be detected in a system.

Figure 2 shows the sequence of events previously described. The bar at the bottom of Figure 2 shows the activity of the microcontroller and is important for very low-power applications. It is possible to construct an MSP430 detector that consumes only 10 μA to 20 μA per key. An example in which this is important is a remote control, where detection is always on.

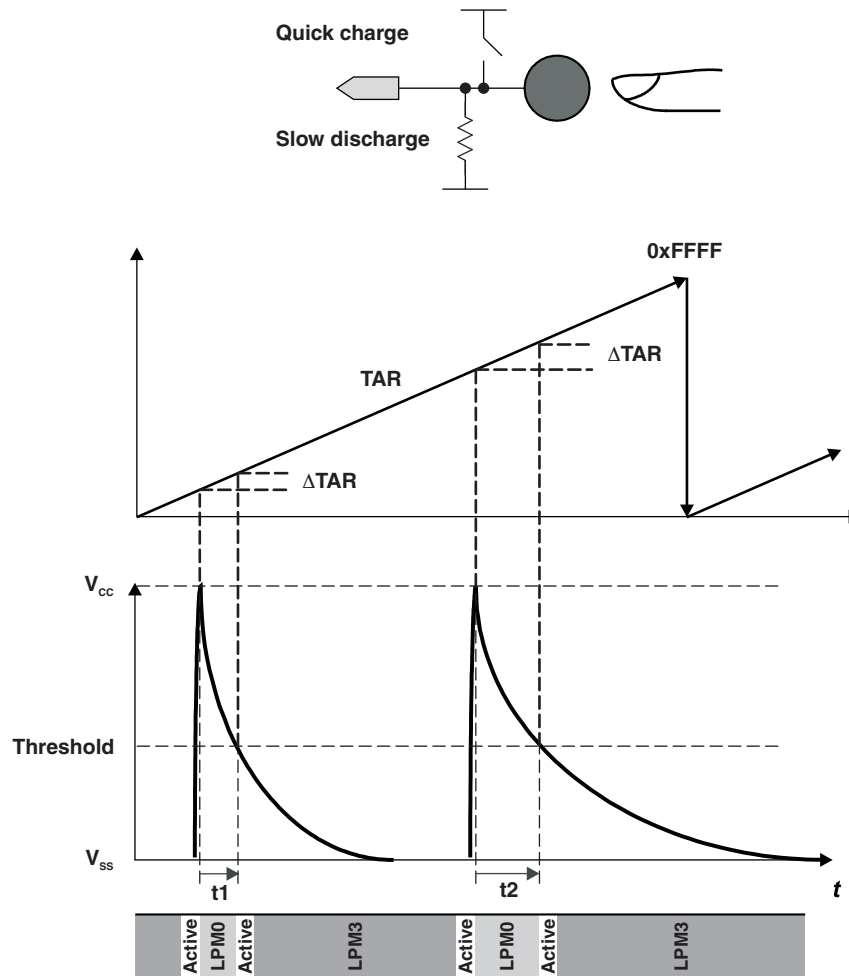

Figure 2. Charge-Discharge Sequence

### 3 Techniques to Improve Noise Immunity and Increase Sensitivity

This high-impedance system has inherent low-power merits, but it can also be susceptible to induced noise. This noise can come from the human body, which picks up 50/60-Hz mains interference or supply noise. Two techniques have been developed to deal with these possible noise problems.

In this document, sensitivity is defined as the difference in counts when the finger covers the pad area. It is also referred to as  $C_{\text{delta}}$ .

### 3.1 Pseudo-Differential Measurement

Figure 3 shows a simple hardware technique to filter out common-mode noise, by using a charge and discharge cycle to measure the capacitance. The average of these two measurements is used in the next stage of the calculation.

If these two measurements are conducted in quick succession, the average behaves like a differential measurement, relative to slower common-mode noise. For example, noise from the mains can be reduced in this way.

The charging and discharging cycles have different threshold levels. Therefore, there is a residue static offset component that translates into an additional capacitance offset. Since the application is designed to detect and measure a change of capacitance from its base or normal value, adding an offset to this normal capacitance does not pose a problem to the detection.

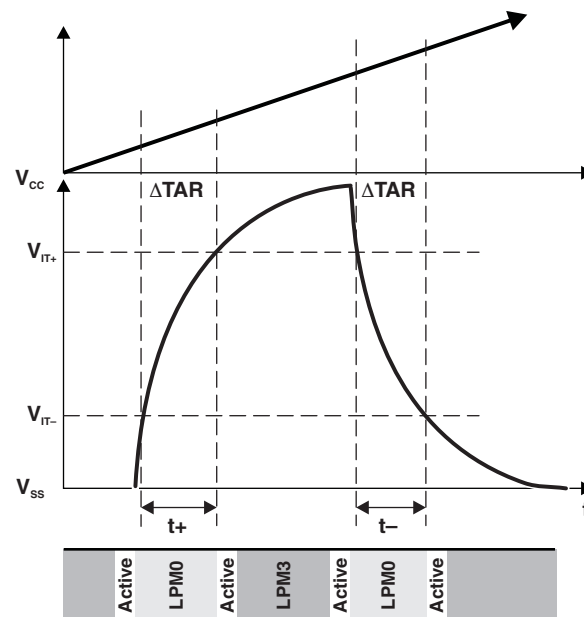

Figure 3. Measurement Cycle for Improved Noise Rejection

To implement this scheme, the resistor is connected between the two I/O lines (see Figure 4). When P1.0 is used to sense its touchpad, P1.1 is turned to output mode and acts as the source and the sink supply for the charge and discharge cycles. When P1.1 is used to sense its touchpad, P1.0 is turned to output mode and acts as the source and the sink supply for the charge and discharge cycles. This has the additional advantage of reducing the number of resistors needed by half.

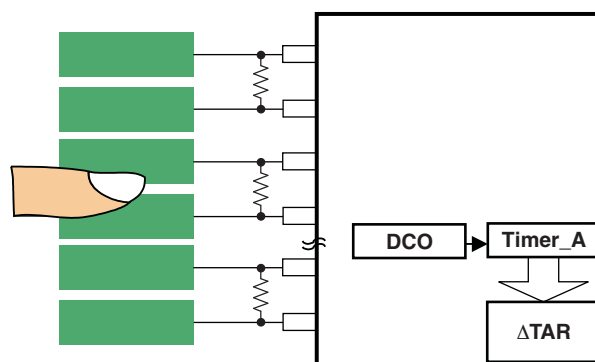
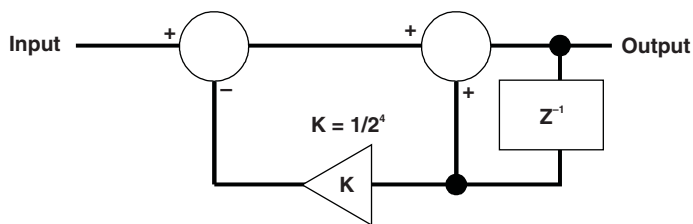

Figure 4. Multi-Sensor Charge/Discharge Configuration

### 3.2 Software Low-Pass Filter

The output of the previous stage goes through an additional IIR filter. This is essentially a dc tracking filter. This filter removes any residue noise and increases the sensitivity of the pad. A bit of speed is sacrificed, but the overall effect is beneficial. Figure 5 shows the structure of the filter.



**Figure 5. Software Low-Pass Filter**

The input is the difference between the instantaneous capacitance reading of a pad and its base capacitance value. This base capacitance value is evaluated when the pad is in the open state.

Figure 6 is a screen shot of the oscilloscope program. It continuously captures the capacitance changes when a finger touches a sensor with a 1-mm thick plastic overlay. The presence of the 50/60-Hz mains pickup can be clearly seen.

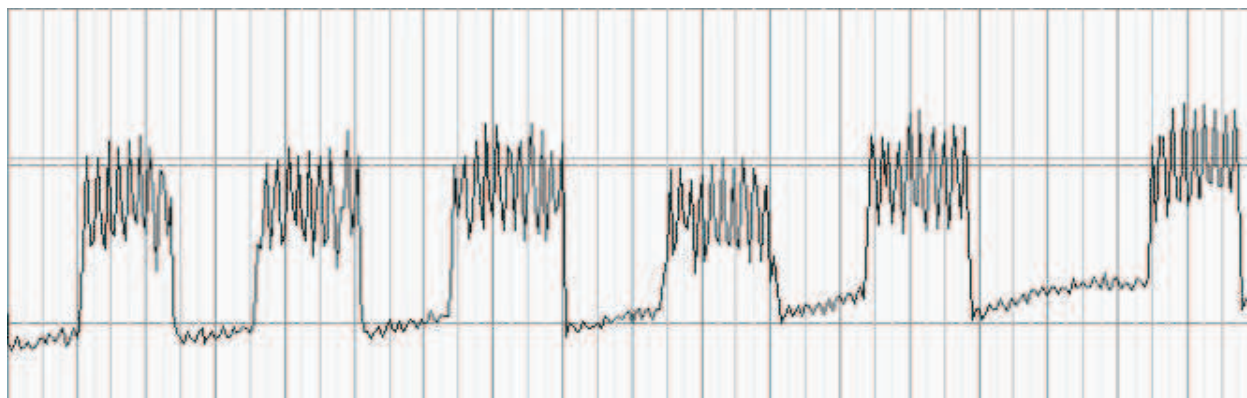

**Figure 6. Oscilloscope With Mains Noise**

Figure 7 shows the structure of the simple IIR filter and the a much improved results when a software digital filter is added to reject the 50/60-Hz mains noise. The filter also amplifies the signal.

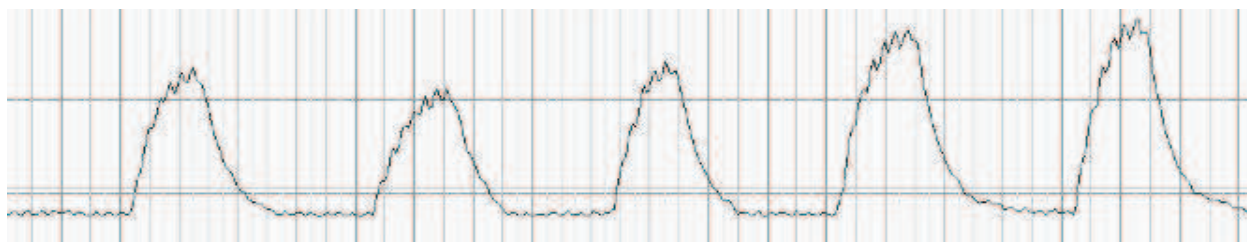

**Figure 7. Oscilloscope With IIR Filter**

### 3.3 Tracking Base Capacitance Value

The base capacitance of the touchpad (the capacitance when the touchpad is in open air) can change with temperature. Therefore, it is important to track this slow change. The tracking cycle time is typically in minutes rather than seconds. Also the tracking speed is asymmetric in that it is necessary to track increases slower than decreases (a factor of 10 is adopted in this application).

For example, if a finger slowly approaches the touchpad, the adaptation should be slow enough not to desensitize the touchpad. When the finger is withdrawn, the adaptation quickly tracks back to the original open air value. [Figure 8](#) shows this process.

When the touchpad is activated by the finger, the adaptation is stopped.

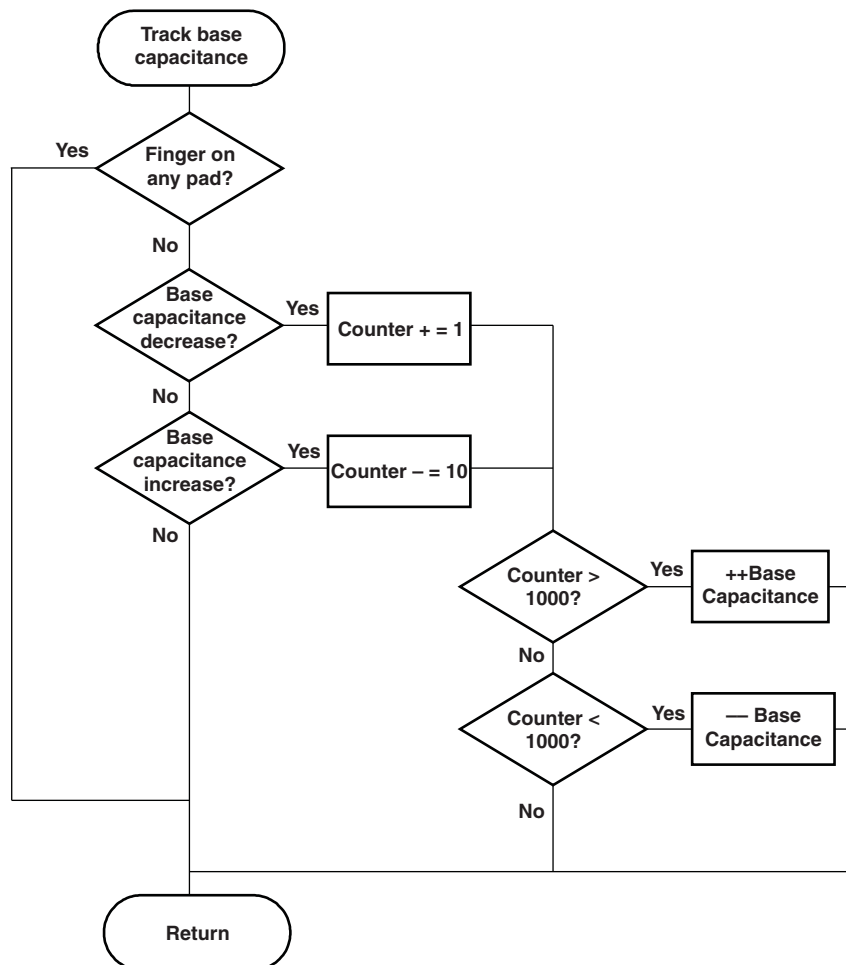
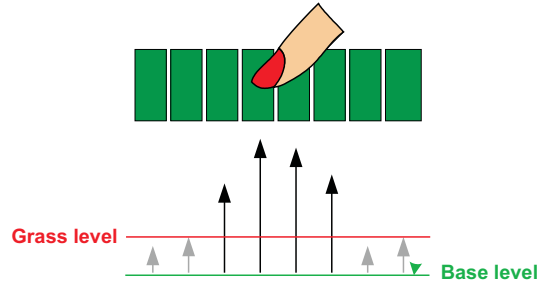

Figure 8. Tracking Base Capacitance Flow Chart

#### 4 Processing Measurement Result

The result of the IIR output should be clean capacitance values with good sensitivity. A simple button-by-button measurement or a slider based on these results is made. In this application example, a slider is built using 14 pads joined together in a telephone dialer shape (see [Figure 9](#)).



**Figure 9. Slider Function**

To build a slider function, a weighted averaging method is used (see [Figure 10](#)). This method yields a finer grain positioning in between two physical pads of 16 intermediate steps. Thus, the slider provides a total of 240 steps for 16 keys.

$$C_{HiRes} = \frac{\sum_{i=1}^{i=n} [(i) \times (C_{\Delta} [i - 1] - C_{\Delta} \text{ min})]}{\sum_{i=1}^{i=n} (C_{\Delta} [i - 1] - C_{\Delta} \text{ min})} \times \text{gain}$$

**Figure 10. Weighted Averaging Method**

[Figure 11](#) shows the output from a finger sliding up and down a strip made up of five multiple capacitive pads. The linearity of the results allows multiple steps per pad, and the resultant peak-to-peak difference is about 60 counts.

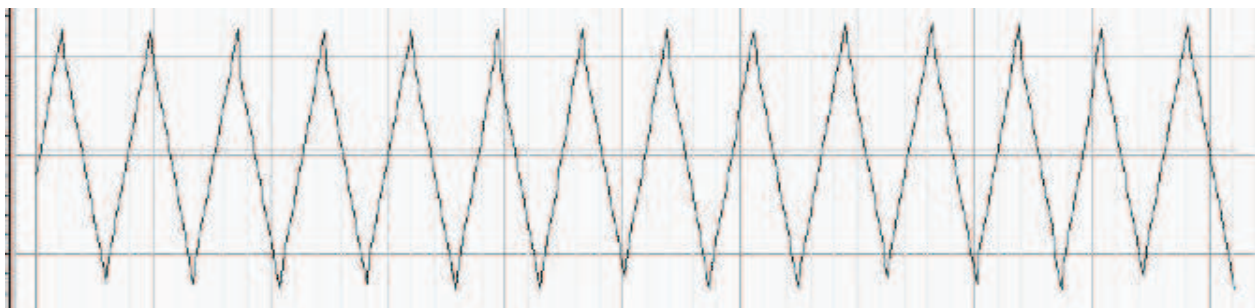

**Figure 11. Slider Output Steps**

## 5 Building an Experimental Board

An MSP430F2013 is used to demonstrate a slider function. The F2013 is part of the MSP-EXP430FG4618 experimenter's board (see [Figure 12](#)).

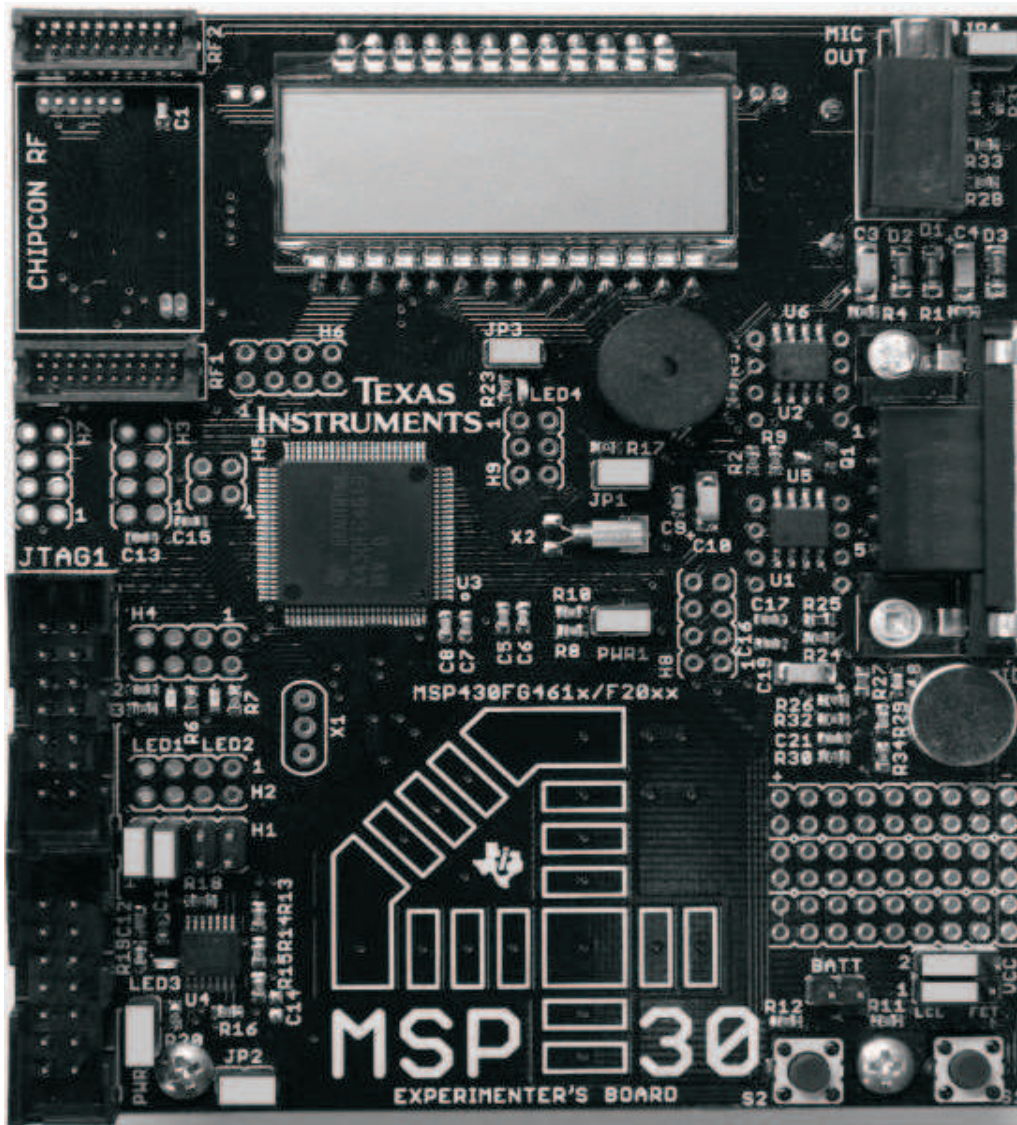
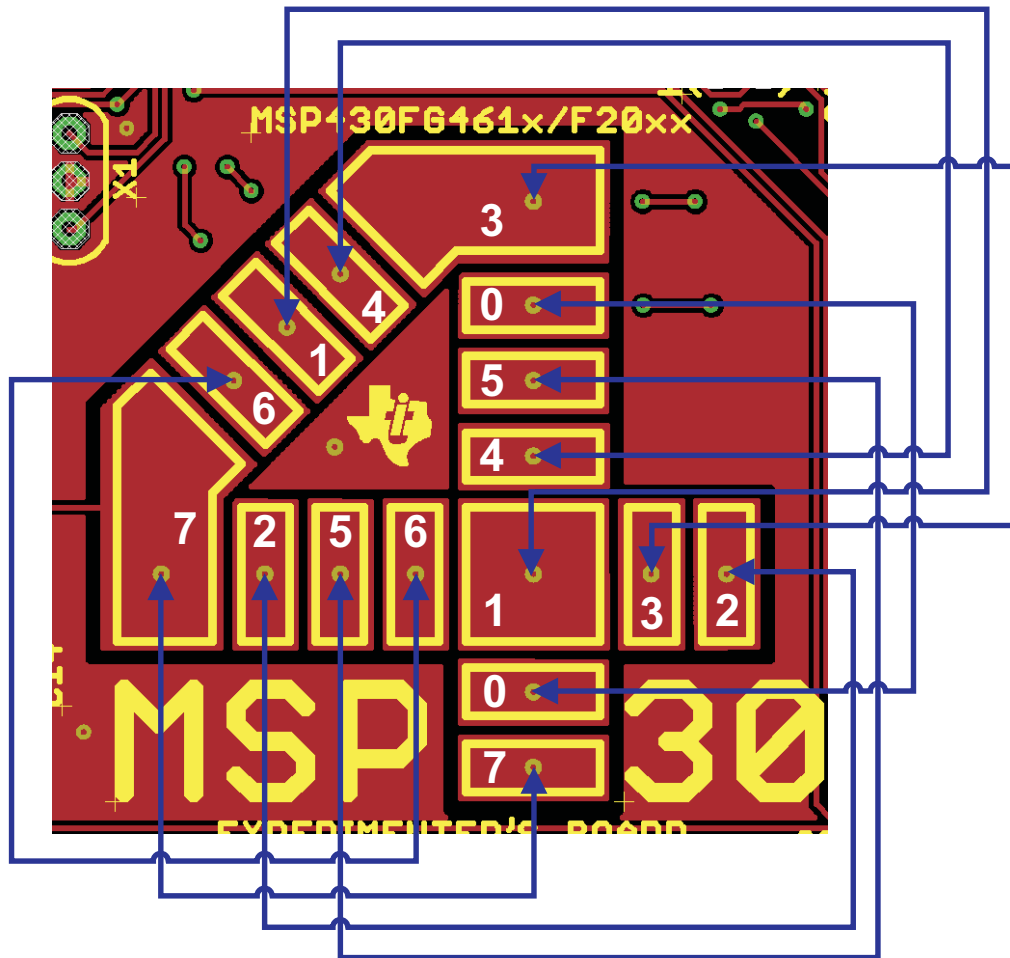

Figure 12. MSP430 Experimenter's Board

The experimenter's board has 16 pads laid out in a shape of the number 4 (see [Figure 13](#)). The I/Os driving these pads are reused.



**Figure 13. Experimenter's Board Pad Layout**

The MSP430 touchpad processor is linked with a host processor, which takes the output from the touchpad and displays it. It also sends the data to a PC, where an application program can display this in different form (see [Figure 14](#)).

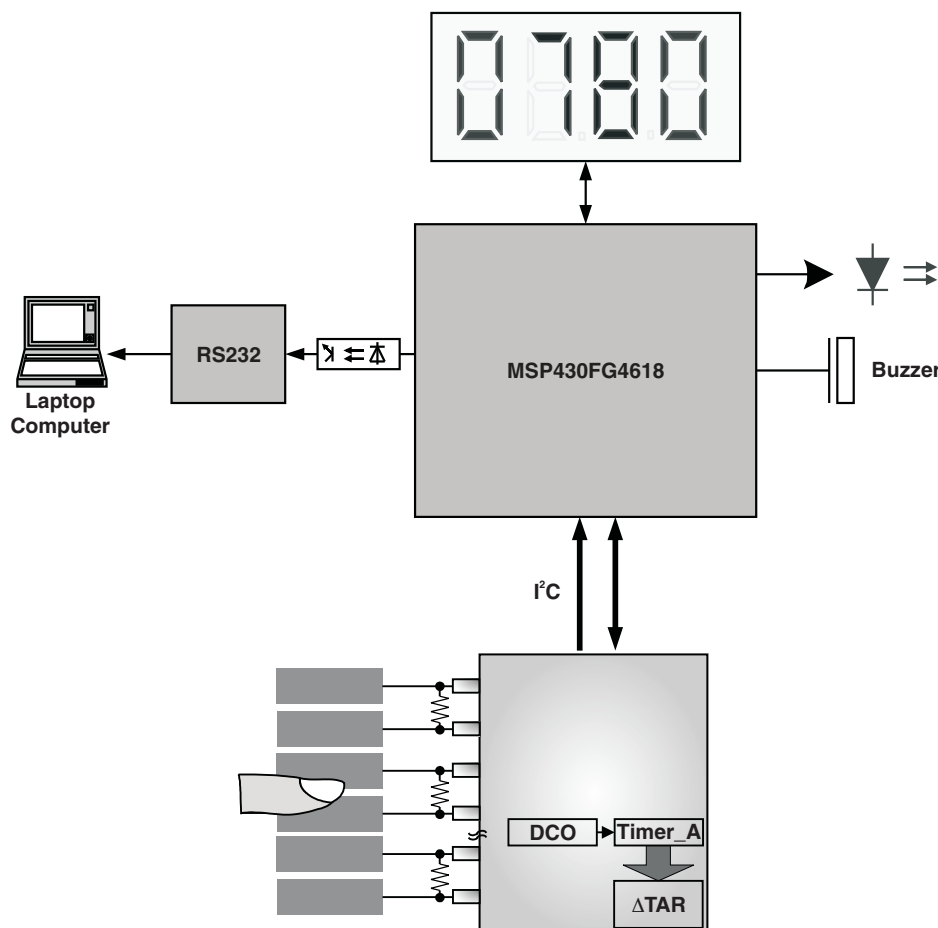

**Figure 14. Touchpad Processor**

## 5.1 Demonstration Examples

The demonstration code runs on the EXP430FG4618 board. To run the experiment, the host software FG4619\_host\_comms must be first loaded onto the U3 by connecting the FET tool to the top JTAG connector. Also, a program running on the PC (touch\_strip.exe) is run with the serial port COM1 connected to the board. The application program can then be loaded onto U4, the target device.

There are two application examples included in this application report:

- Use five of the pads (pads 7, 6, 1, 4, and 3) to produce a slide bar function and output a count from 1 to 255  
As the finger moves along the slider, the reading is sent via I<sup>2</sup>C to the host processor (MSP430FG4618), which has an LCD driver. The number is displayed as an incrementing or decrementing number. Also, a program running on the PC, touch\_strip.exe., displays this number on a volume bar (the number is sent via a UART).
- Use five of the pads (pads 1, 3, 0, 6, and 4) to detect the key pressed from 1 to 5  
As the finger presses each button, the number is sent via I<sup>2</sup>C to the host processor (MSP430FG4618). The key number is displayed, and an arrow pointing to the direction of the key pressed (4 = up, 0 = down, 3 = right, and 6 = left) is displayed on the LCD screen and on the PC program touch\_strip.exe via the UART.

## 6 System Resources

For the slider application previously described with I<sup>2</sup>C communication, the system resources used are:

- 1950 bytes of ROM
- 96 bytes of RAM
- Less than 0.1 MIPS

The actual MIPS requirement is very small, since the processor spends most of its time in sleep mode.

Only the RAM size needs to be increased proportionally when the number of keys increases to 16.

## 7 Board Layout Considerations

### 7.1 Connecting Circuits to Touchpads

The connecting wire to the touchpad should be kept short, because the wire adds to the base capacitance. It is also important to keep the connecting wire as stable in shape as possible, because bending can affect the over capacitance change.

Since the touchpad drive circuits are high impedance in nature, avoid putting high-speed or high-current drive wires next to the touchpad wires.

### 7.2 Touchpad Shape and Size

Normal solid filled circular or square pads can be used. The pad can have a hole drilled through it to provide backlighting without influencing the capacitive performance.

The pad is normally surrounded with ground area. Both meshed and solid fill can be used. The clearance to the grounded area often uses a 1/20 ratio of the pad size. If 10-mm pad is used, then the gap of 0.5 mm is suitable (see [Figure 15](#)).

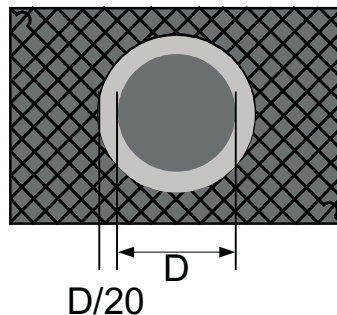

**Figure 15. Touchpad Size and Shape**

In a scroll-bar application, pads are closely packed together. In this case, the neighboring pads are grounded by the devices when not used. This forms a dynamic ground plane around the active pad.

Normally, the larger the pad size, the higher the sensitivity. The limit is when the finger is no longer covering the pad area, in which case further increases in pad sizes produce no further benefits. The clearance between the pad and the ground plane also affects its sensitivity.

In the case of a scroll bar, it is important that the pads are not too big. A normal finger should be able to cover one and one half touchpads.

[Figure 16](#) through [Figure 18](#) show the variation of sensitivity versus pad size and clearance for different overlay thicknesses. The average counts indicate the average difference of counts seen when the finger is on the pad compared to that when the finger is absent. The clock speed used is 8 MHz (maximum speed is 16 MHz).

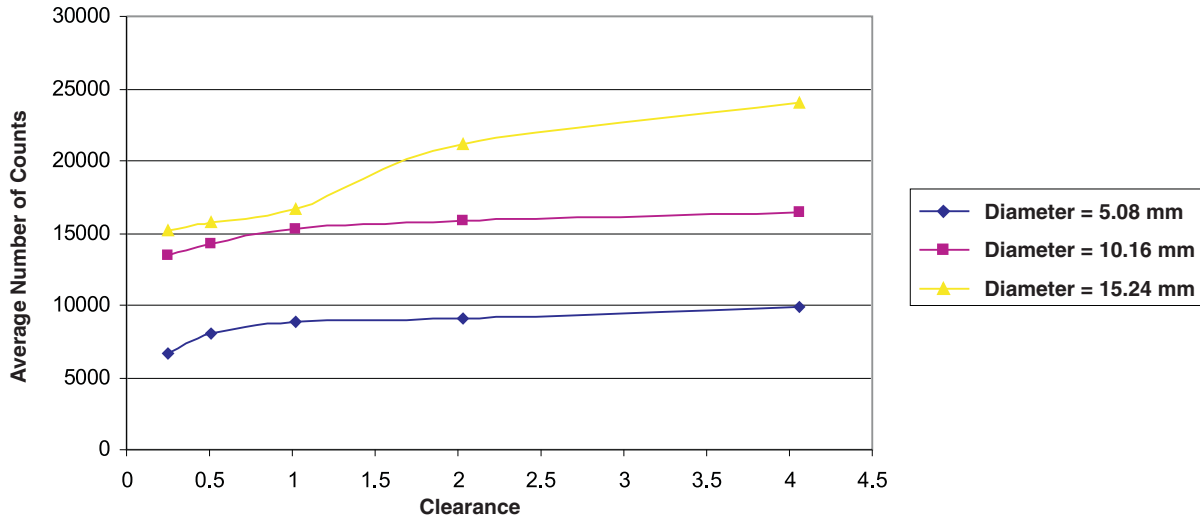

Figure 16. Pad Sensitivity (Overlay Thickness = 0 mm)

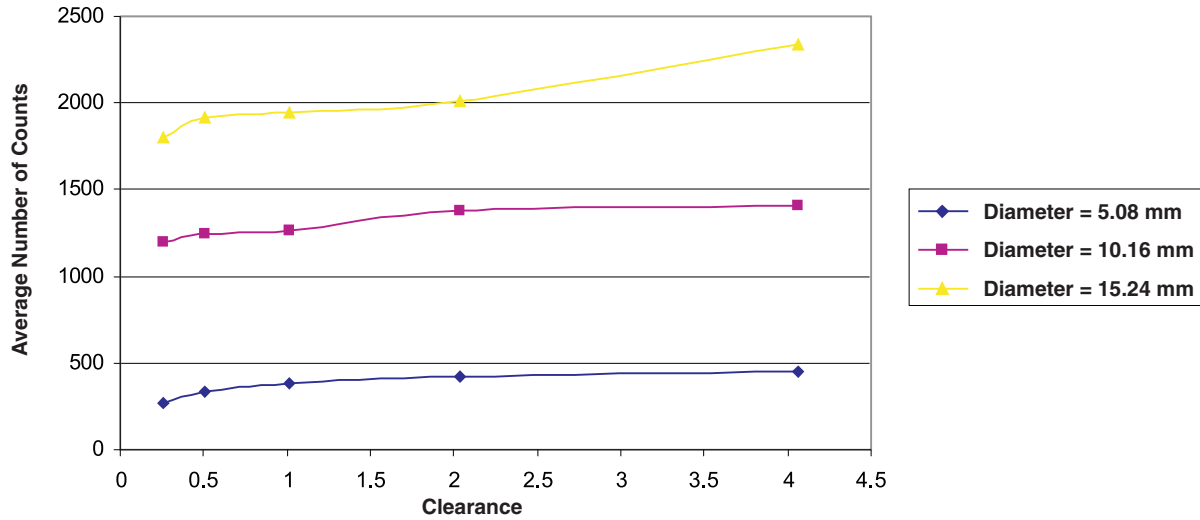

Figure 17. Pad Sensitivity (Overlay Thickness = 0.8 mm)

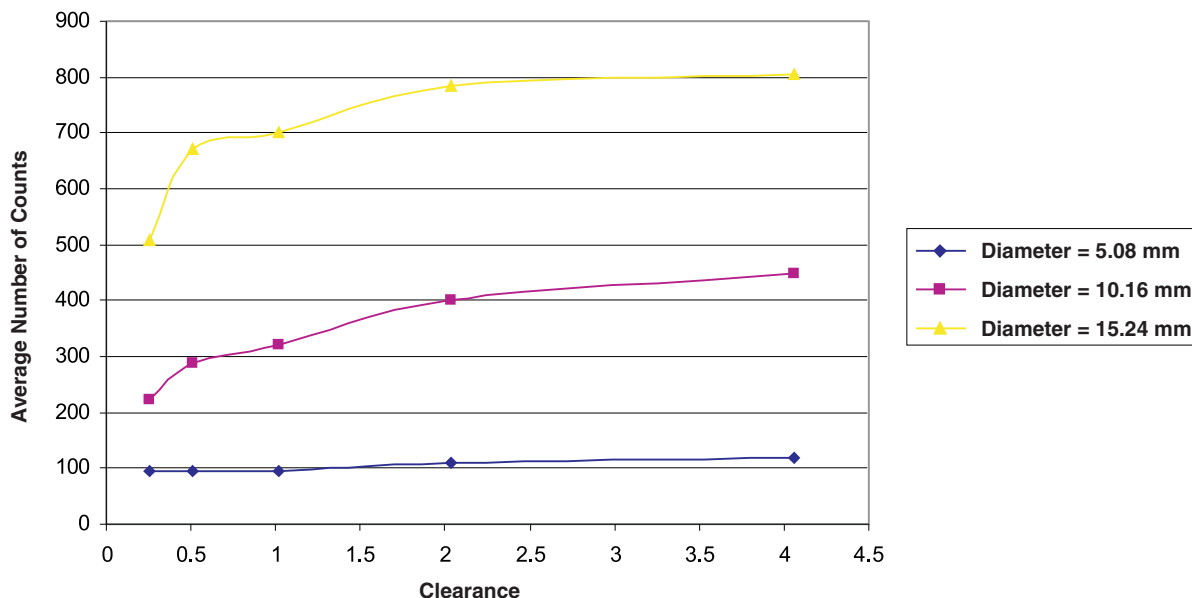

Figure 18. Pad Sensitivity (Overlay Thickness = 2.4 mm)

### 7.3 PCB Thickness and Grounding on Nonactive Surfaces

Since the capacitor sensing board is often placed on top of other electronics, it is often helpful to put grounding on the underside of the PCB to shield the sensors from radiated noise from the electronics underneath.

If FR4 materials are used, the thickness of the PCB has little effect on the sensors. When flexible PCB material like Kapton is used, the thinner material means that the underneath ground plate is brought much closer to the surface sensor pads and can interfere with their capacitive performance. This effect can be reduced by using 40% or less mesh grounding to reduce the coupling area.

## 8 Overlay

### 8.1 Overlay Material

There are two considerations when choosing the overlay materials:

- Capacitive coupling performance (dielectric constant)
- Static breakdown characteristic

Table 1 shows the dielectric constant of some commonly used materials:

Table 1. Dielectric Constants of Common Materials

Material	$\epsilon_r$ (Dielectric Constant)
Air	1.0
Glass	7.6 to 8.0
Mylar	3.2
ABS	3.8 to 4.5
Wood	1.2 to 2.5

The higher dielectric materials give better capacitive coupling between the finger and the sensor plates. Apart from air and some wood, the materials listed are well suited to being overlay materials.

Because air has lower capacitive coupling characteristics, one should try to not leave air gaps between the sensor plate and the overlay material. Air gap can also capture moisture, which can condense onto the sensor surface when the temperature abruptly changes. See [Section 8.3](#) for information on adhesives and filling compounds.

[Table 2](#) shows the minimum thickness to avoid 12-kV damage through the overlay for some commonly used materials:

**Table 2. Minimum Thickness for 12-kV ESD Protection**

Material	Minimum Thickness
FR-4	0.4 mm
Kapton	0.04 mm
Acrylic	0.9 mm
Polycarbonate	0.8 mm
Glass	1.5 mm
ABS	0.8 mm

To increase ESD protection, a layer of Kapton can be added to greatly increase the breakdown tolerance of the overlay.

## 8.2 Overlay Thickness Versus Sensitivity

Overlay thickness is normally inversely proportional to sensitivity, and the relationship is inversely exponential.

A number of factors can influence the sensitivity of the capacitive sensing pads:

- Pad size
- Overlay material and its thickness
- Gain of the sensing method (including IIR filter gain and clock speed)

[Table 3](#) shows typical overlay thickness versus the type of capacitor sensor application at an 8-MHz clock and an IIR filter gain of 4.

**Table 3. Typical Overlay Thickness**

Application	Typical Thickness
Button	<5.0 mm
Slider	<1 mm

Figure 19 and Figure 20 show the sensitivity of the circuit versus different overlay thicknesses. The sensitivity is expressed as delta count (finger on and finger off).

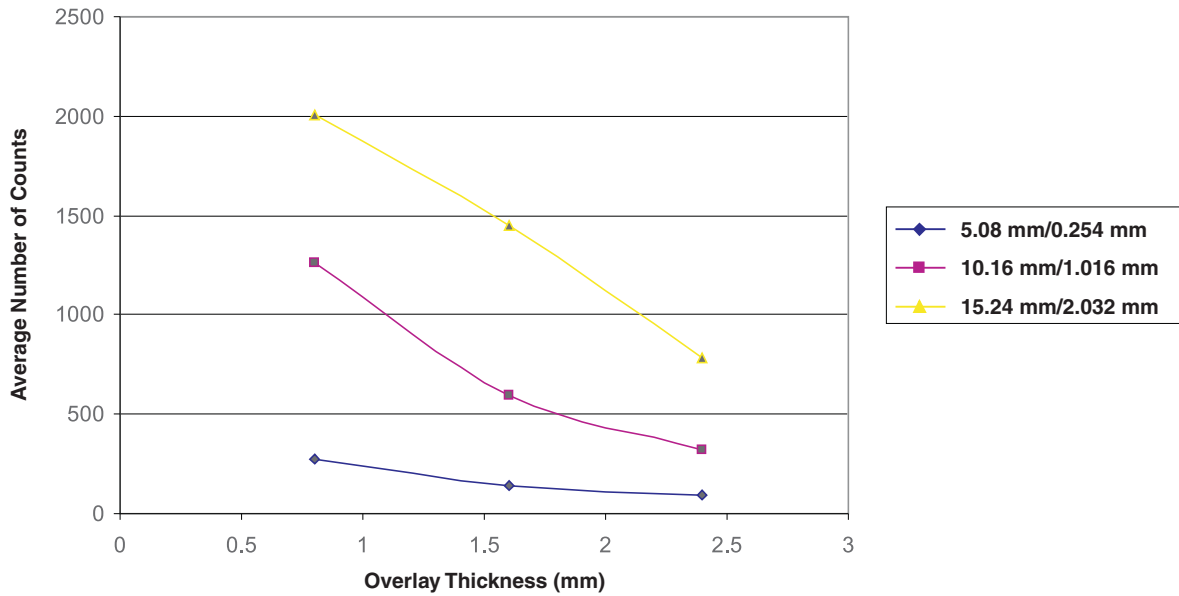

Figure 19. Overlay Thickness vs Sensitivity

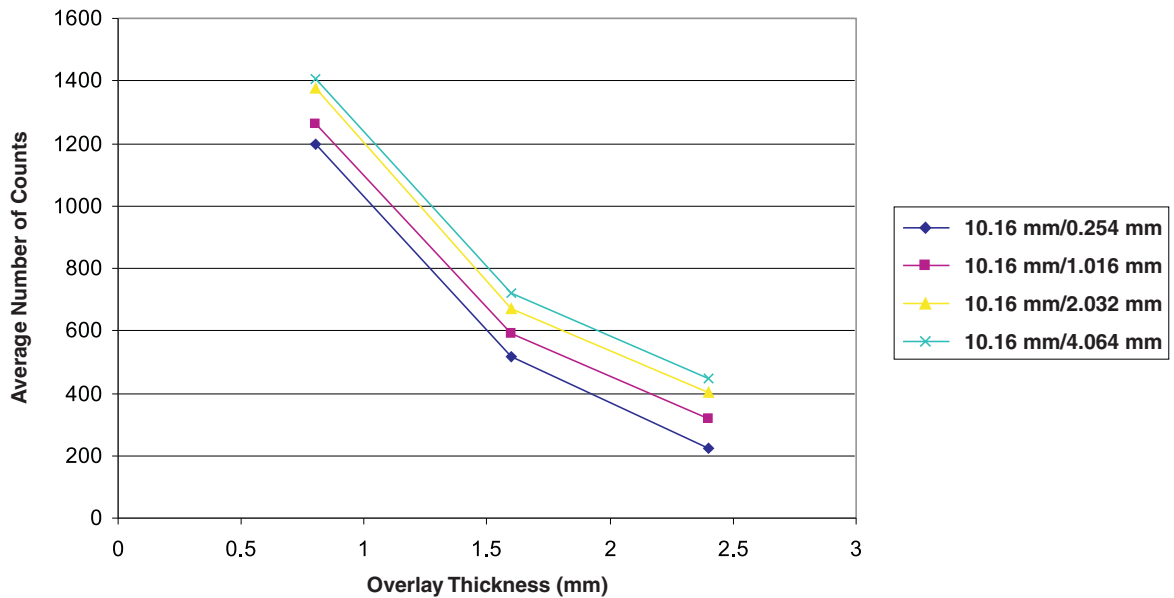

Figure 20. Effects of Clearance and Overlay Thickness vs Sensitivity

### 8.3 Adhesives and Other Filling Compounds

In most applications, there should be an airtight coupling between the sensor electrodes and the overlay material. Designers can choose between filling sheets with the PCB board pressed against the overlay material mechanically or with adhesives. There are two considerations when choosing the adhesive:

- The material should not carry charge and influence the capacitive performance (therefore, it should be a dielectric).
- The material should not absorb moisture.

3M™ 467MP and 468MP high-performance acrylic double-sided adhesive tape, with a 4.2-mil 58-lb polycoated kraft liner, is a good choice for this application.

### 8.4 Radio-Frequency (RF) Emission and Susceptibility Test Results

Many of the applications for touchpads are in personal portable products, which are used close to strong RF sources, such as cellular telephones. Clearly, immunity to such sources is very important for success. The experimenter's board was used as a test bed to evaluate performance in this area. It was tested against the requirements of EN55024 in an electromagnetically sealed anechoic test room.

The presence of a finger clearly affects the level of both RF pickup and radiation. Realistic tests must allow for this. However, a frequency sweep test takes considerable time. It is not practical to have a human being in a sealed chamber holding still for an hour. A concentrated solution of common salt (sodium chloride) is widely used as a simulation of the human body in testing personal radio products. A plastic bag was filled with saturated salt solution and sealed. A corner of the bag was attached to the touchpad with thin double-sided adhesive tape to simulate a finger. The response of the touchpad was approximately the same as with a real adult finger.

The following items were inside the sealed room:

- The experimenter's board under test, powered by its on board battery
- An antenna to either radiate (for susceptibility tests) or receive (for emission tests), along a well controlled axis pointing at the board under test
- Another antenna monitoring the field strength

For the emission tests, a spectrum analyzer outside the room was connected to the main antenna in the room.

More test equipment was used for the susceptibility tests. Outside the room was an RF signal generator, able to generate carrier frequencies between 30 MHz and 1 GHz. This was connected to a 25-W RF amplifier with a similar frequency range, which in turn was connected to the main antenna in the room. A field strength meter was attached to the other antenna in the room and monitored throughout the frequency sweep tests. An RS232C lead was connected from the experimenter's board to a PC outside the room. Since this port was optically isolated from the rest of the board, the lead had little influence on the tests.

The emissions from the board were measured using the spectrum analyzer with the board in various orientations, with and without the bag of salt water attached. The only time anything was readily visible above the basic noise of the test equipment was without the salt water and with the antenna pointing directly toward the 9-pin RS232C connector on the experimenter's board. Here, a small response was seen at 134.5 MHz. Even this response was far below the emission level allowed by EN55024. Presumably something on the board resonates at this frequency, since it is many times the frequency of any clock signal on the board (see [Figure 21](#)).

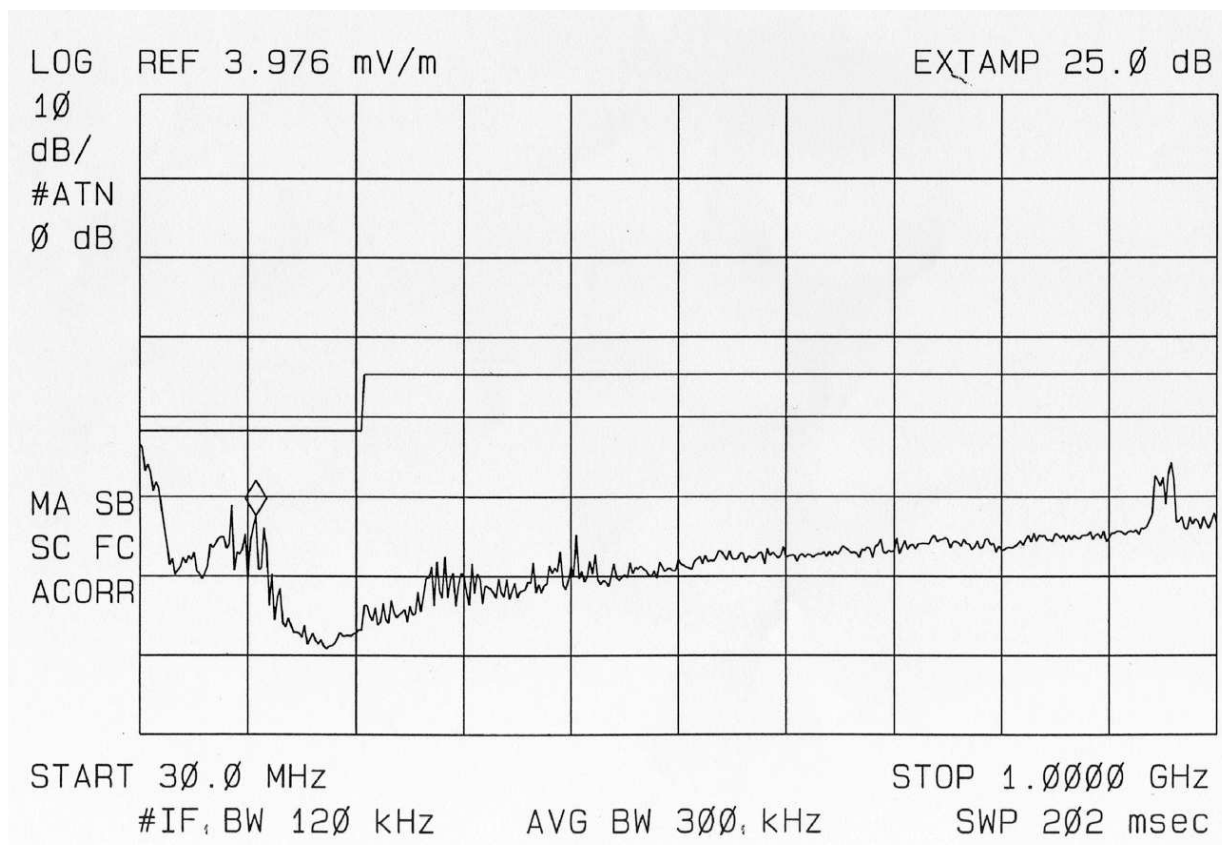

**Figure 21. RF Emissions**

## References

The susceptibility tests consisted of sweeping the signal generator from 30 MHz to 1 GHz at a very slow rate, so any narrow-band problems that might exist had plenty of time to become visible. During these sweeps, the MSP430F2013 software was sending the size of each response from the touchpad through its RS232C interface to the external PC. For constant signal strength, the measured field strength varied with the frequency of the generator. EN55024 requires the tests be conducted at a minimum field strength of 3 V/m. The signal strength was adjusted during the frequency sweeps to keep the field strength between 3 V/m and 4 V/m. Frequency sweeps were conducted with and without the bag of salt water attached to the touchpad. The sensitivity margin is approximately 750 counts at the worst frequency (see Figure 22).

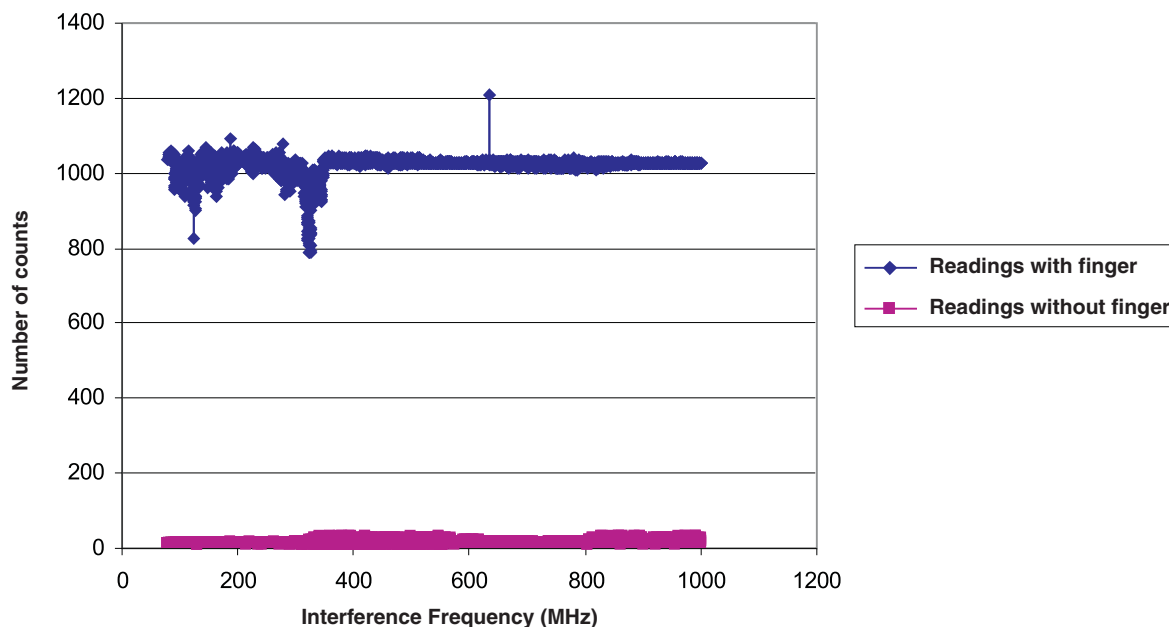

**Figure 22. RF Interference Susceptibility**

## 9 References

1. US Patent 3931610, *Capacitive Keyswitch Sensor and Method*
2. *MSP430x2xx User's Guide* ([SLAU144](#))
3. Cypress Semiconductor application note (AN2992)
4. *PCB-Based Capacitive Touch Sensing With MSP430* ([SLAA363](#))

## IMPORTANT NOTICE

Texas Instruments Incorporated and its subsidiaries (TI) reserve the right to make corrections, modifications, enhancements, improvements, and other changes to its products and services at any time and to discontinue any product or service without notice. Customers should obtain the latest relevant information before placing orders and should verify that such information is current and complete. All products are sold subject to TI's terms and conditions of sale supplied at the time of order acknowledgment.

TI warrants performance of its hardware products to the specifications applicable at the time of sale in accordance with TI's standard warranty. Testing and other quality control techniques are used to the extent TI deems necessary to support this warranty. Except where mandated by government requirements, testing of all parameters of each product is not necessarily performed.

TI assumes no liability for applications assistance or customer product design. Customers are responsible for their products and applications using TI components. To minimize the risks associated with customer products and applications, customers should provide adequate design and operating safeguards.

TI does not warrant or represent that any license, either express or implied, is granted under any TI patent right, copyright, mask work right, or other TI intellectual property right relating to any combination, machine, or process in which TI products or services are used. Information published by TI regarding third-party products or services does not constitute a license from TI to use such products or services or a warranty or endorsement thereof. Use of such information may require a license from a third party under the patents or other intellectual property of the third party, or a license from TI under the patents or other intellectual property of TI.

Reproduction of TI information in TI data books or data sheets is permissible only if reproduction is without alteration and is accompanied by all associated warranties, conditions, limitations, and notices. Reproduction of this information with alteration is an unfair and deceptive business practice. TI is not responsible or liable for such altered documentation. Information of third parties may be subject to additional restrictions.

Resale of TI products or services with statements different from or beyond the parameters stated by TI for that product or service voids all express and any implied warranties for the associated TI product or service and is an unfair and deceptive business practice. TI is not responsible or liable for any such statements.

TI products are not authorized for use in safety-critical applications (such as life support) where a failure of the TI product would reasonably be expected to cause severe personal injury or death, unless officers of the parties have executed an agreement specifically governing such use. Buyers represent that they have all necessary expertise in the safety and regulatory ramifications of their applications, and acknowledge and agree that they are solely responsible for all legal, regulatory and safety-related requirements concerning their products and any use of TI products in such safety-critical applications, notwithstanding any applications-related information or support that may be provided by TI. Further, Buyers must fully indemnify TI and its representatives against any damages arising out of the use of TI products in such safety-critical applications.

TI products are neither designed nor intended for use in military/aerospace applications or environments unless the TI products are specifically designated by TI as military-grade or "enhanced plastic." Only products designated by TI as military-grade meet military specifications. Buyers acknowledge and agree that any such use of TI products which TI has not designated as military-grade is solely at the Buyer's risk, and that they are solely responsible for compliance with all legal and regulatory requirements in connection with such use.

TI products are neither designed nor intended for use in automotive applications or environments unless the specific TI products are designated by TI as compliant with ISO/TS 16949 requirements. Buyers acknowledge and agree that, if they use any non-designated products in automotive applications, TI will not be responsible for any failure to meet such requirements.

Following are URLs where you can obtain information on other Texas Instruments products and application solutions:

### Products

Amplifiers	<a href="http://amplifier.ti.com">amplifier.ti.com</a>
Data Converters	<a href="http://dataconverter.ti.com">dataconverter.ti.com</a>
DSP	<a href="http://dsp.ti.com">dsp.ti.com</a>
Clocks and Timers	<a href="http://www.ti.com/clocks">www.ti.com/clocks</a>
Interface	<a href="http://interface.ti.com">interface.ti.com</a>
Logic	<a href="http://logic.ti.com">logic.ti.com</a>
Power Mgmt	<a href="http://power.ti.com">power.ti.com</a>
Microcontrollers	<a href="http://microcontroller.ti.com">microcontroller.ti.com</a>
RFID	<a href="http://www.ti-rfid.com">www.ti-rfid.com</a>
RF/IF and ZigBee® Solutions	<a href="http://www.ti.com/lprf">www.ti.com/lprf</a>

### Applications

Audio	<a href="http://www.ti.com/audio">www.ti.com/audio</a>
Automotive	<a href="http://www.ti.com/automotive">www.ti.com/automotive</a>
Broadband	<a href="http://www.ti.com/broadband">www.ti.com/broadband</a>
Digital Control	<a href="http://www.ti.com/digitalcontrol">www.ti.com/digitalcontrol</a>
Medical	<a href="http://www.ti.com/medical">www.ti.com/medical</a>
Military	<a href="http://www.ti.com/military">www.ti.com/military</a>
Optical Networking	<a href="http://www.ti.com/opticalnetwork">www.ti.com/opticalnetwork</a>
Security	<a href="http://www.ti.com/security">www.ti.com/security</a>
Telephony	<a href="http://www.ti.com/telephony">www.ti.com/telephony</a>
Video & Imaging	<a href="http://www.ti.com/video">www.ti.com/video</a>
Wireless	<a href="http://www.ti.com/wireless">www.ti.com/wireless</a>

Mailing Address: Texas Instruments, Post Office Box 655303, Dallas, Texas 75265  
Copyright 2008, Texas Instruments Incorporated